

RASONIC REV-J8 Series

AC EV Charging Station



User Manual

UM14B102-1:2024

About this User Manual

Read carefully before installation, maintenance, and operation!

- ▶ Failure to read this manual carefully may lead to improper operation.
- ▶ Failure to follow the safety notes may lead to a danger of death, injury and damage to the device, supplier cannot accept any liability for claims resulting from this.

Thank you very much to use RASONIC AC EV Charging Station.

- ▶ This manual describes the installation, use and maintenance of RASONIC. This manual is intended for installation and maintenance personnel.

Article	Model Number
1-phase, 7kW, with 5m charging cable	REV-J8132
3-phase, 22kW, with 5m charging cable	REV-J8332
1-phase, 7kW, with 7.5m charging cable	REV-J8132S
3-phase, 22kW, with 7.5m charging cable	REV-J8332S

- ▶ The text and illustrations in this user manual are general explanations of these type of RASONIC, and the actual product may be inconsistent with this manual in detail.

All rights reserved.

CONTENTS

1. ABBREVIATIONS	4
2. SAFETY NOTES	5
2.1. Safety signs used	5
2.2. Environment	6
2.3. Installation	6
2.4. Operation	7
2.5. Maintenance	7
3. STANDARDS COMPLIANCE	8
3.1. Charging mode	8
3.2. Charging connection	8
3.3. Charging interface	9
4. PRODUCT INFORMATION	10
4.1. General	10
4.2. Model number definition	11
4.3. Specifications	11
4.3.1. Electrical specifications	11
4.3.2. Functional description	12
4.3.3. Ambient conditions	12
4.3.4. Mechanical parameters	12
4.4. Nameplate	13
5. INSTALLATION	14
5.1. Unpacking	14
5.1.1. Packing list	14
5.1.2. Inspection & confirm	14
5.2. Prepare	15
5.3. Power supply system	16
5.4. Installation steps	18
5.5. Empty socket	21

6. OPERATION	22
6.1. Power on.....	22
6.2. Human-Machine Interface	22
6.2.1.Overview.....	22
6.2.2.LCD indicators.....	22
6.2.3.RFID reader.....	24
6.2.4.LED indicators.....	25
6.2.5.Charging control button.....	25
6.3. Configure parameters.....	26
6.4. Start Charging.....	28
6.5. Normally stop charging.....	29
6.6. Abnormally stop charging	29
7. FAULT HANDLING AND MAINTENANCE.....	30
7.1. Fault Handling	30
7.2. Maintenance.....	31
8. TECHNICAL GUIDELINES ON CHARGING FACILITIES FOR ELECTRIC VEHICLES	32
9. SPECIAL AVOWAL	32
10. AFTER SALES SERVICES	32
DECLARATION OF CONFORMITY(DOC).....	34
COMPLIANCE STATEMENT OF WEEE.....	35

1. ABBREVIATIONS

S/N	Abbreviations	Description
1	IEC	International Electrotechnical Commission
2	EV	Electrical Vehicle, this can be BEV (battery EV) or PHEV (plug-in hybrid EV)
3	EVSE	Electric Vehicle Supply Equipment [IEC61851-1]
4	OBC	On-board charger (of an EV)
5	LCD	Liquid Crystal Display
6	LED	Light-emitting Diode
7	RFID	Radio Frequency Identification
8	CMS	Central Management System
9	OCPP	Open Charge Point Protocol
10	IP	Ingress Protection
11	HMI	Human-Machine Interface
12	RCMU	Residual Current Monitoring Unit
13	MCB	Miniature Circuit Breaker

"T" — indicates the connection between earth and the power supply is direct connection of a point with earth (French: Terre).

"N" — the earth connection is supplied by the electricity supply network, either separately to the neutral conductor (TN-S), combined with the neutral conductor (TN-C), or both (TN-C-S).

14	TN	<div style="display: flex; justify-content: space-around;"> <div style="text-align: center;"> <p>TN-S system 230/400VAC</p> </div> <div style="text-align: center;"> <p>TN-C system 230/400VAC</p> </div> <div style="text-align: center;"> <p>TN-C-S system 230/400VAC</p> </div> </div>
15	PE	Protective Earth. The conductor that connects the exposed metallic parts of the consumer's electrical installation
16	PEN	PEN line is to accurately and well ground the original neutral line, and connect the shell of the equipment to be protected to the PEN line

2. SAFETY NOTES

2.1. Safety signs used

The following warning signs, mandatory signs and information signs are used in this manual, on and in the RASONIC AC EV Charging station.



CAUTION: Warning of electrical hazards.
This sign is intended to alert the user that severe personal injury or substantial property damage can result if the device is not operated as requested.



ATTENTION: Warning of a danger spot or dangerous situation.
This sign is intended to alert the user that minor personal injury or material damage can result, if the device is not operated as requested.



CAUTION: Do not touch by hands in case of ESD.
Indicates the possible consequences of touching electrostatically sensitive components.



CAUTION: Warning of combustion.



No access for unauthorized persons.



No access for persons wearing pacemakers.



Use protective footwear.



Must wear a safety helmet.



Indicates important texts, notes or tips.



Indicates recycling information.



Indicates assemblies or parts that must be disposed of properly.
Do not dispose of them in the household waste.

2.2. Environment



- ▷ EV Charging station should be installed on the incombustible such as concrete; otherwise, hazardous fire may result.
- ▷ EV Charging station should not be installed in the area that contains explosive gas; otherwise, hazardous blast may result.
- ▷ Leave no inflammable or explosive substances near the EV Charging station; otherwise, hazardous blast may result.



- ▷ EV Charging station should be installed in a place with no conductive dust and insulation-destructive gas or vapor.
- ▷ EV Charging station should be installed in a place with no violent vibration and impact; for good ventilation, mount the charging station vertically.
- ▷ The installation foundation shall be higher than the ground level, and drainage ditch shall be set around the EV Charging station, otherwise the equipment may be damaged.

2.3. Installation



Safety protection must be done when installing the RASONIC EV Charging station.



- ▷ Installation and wiring should be done by personnel with professional qualification, otherwise, hazardous electric shock may result.
- ▷ Make sure input power supply is entirely disconnected before wiring; otherwise, hazardous electric shock may result.
- ▷ PE terminal of the EV Charging station must be grounded securely; otherwise, hazardous electric shock may result.
- ▷ The lead nose of the charging station must be securely attached or there is a risk of damaging the equipment.
- ▷ Leave no metals such as bolts, gaskets into the inside of the EV Charging station; otherwise, hazardous blast and fire may result.



- ▷ Main loop terminal of the EV Charging station should be firmly connected with the wiring ends; otherwise, damage to property may result.
- ▷ Bare parts of wiring ends of electrical cables must be wrapped with insulating tape; otherwise, hazardous fire and property loss may result.

2.4. Operation



▷ Strictly forbidden for minors or persons of restricted capacity to approach the charging station to avoid injury.

▷ Forced charging is strictly forbidden when the electric vehicle or charging station fails.



▷ It is strictly prohibited to use the charging station when the charging adapter or charging cables are defective, cracked, worn, broken or the charging cables is exposed. If you find any, please contact the supplier in time.

▷ EV can only be charged with the engine off and stationary.



▷ Do not charge in rainy and thunderous weather.

2.5. Maintenance



Personnel must always use protective footwear when maintenance work.

Caution ESD to avoid damaging electronic devices, especially to protect microchips on PCBA.



▷ Accessory replacement must be done by qualified personnel, thrums or metals are prohibited to be left in the controller; otherwise, hazardous blast and fire may result.



▷ After replacing main PCBA, parameters must be adjusted and matched before operation; otherwise, property loss may result.

▷ It is recommended that routine safety inspection visits to charging station be conducted at least once a week.

▷ Keep the charging connector clean and dry and wipe with a clean, dry cloth if soiled.

3. STANDARDS COMPLIANCE

3.1. Charging mode

- Conformed to *EN IEC 61851-1:2019*.



Charging mode:

method for connection of an EV to the supply network to supply energy to the vehicle

- The Charging mode of RASONIC is Mode 3.



Mode 3 is a method for the connection of an EV to an AC EV supply equipment permanently connected to an AC supply network, with a control pilot function that extends from the AC EV supply equipment to the EV.

3.2. Charging connection

- According to *EN IEC 61851-1:2019*, RASONIC meet the Case C connection.



Case C:

Connection of an EV to a supply network utilizing a cable and vehicle connector permanently attached to the EV charging station.

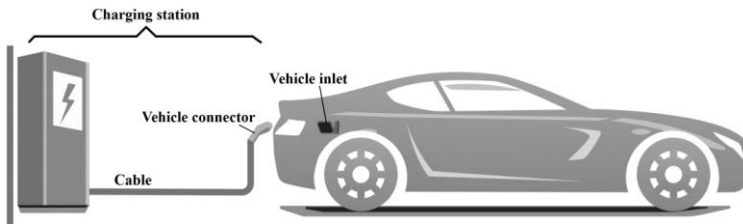

Fig. 3-1 Schematic diagram of CASE C connection

3.3. Charging interface

- The charging connector of RASONIC meet IEC 62196-2, Type 2 plug (with charging cable).



Fig. 3-2 Type 2 plug on RASONIC

- RASONIC provide a Type 2 female plug with charging cable, it only charging an EV with a Type 2 vehicle inlet.

4. PRODUCT INFORMATION

4.1. General

Welcome to use RASONIC AC EV Charging station produced by our company.

- The shape & dimensions of RASONIC AC EV charging station shown as Fig. 4-1.

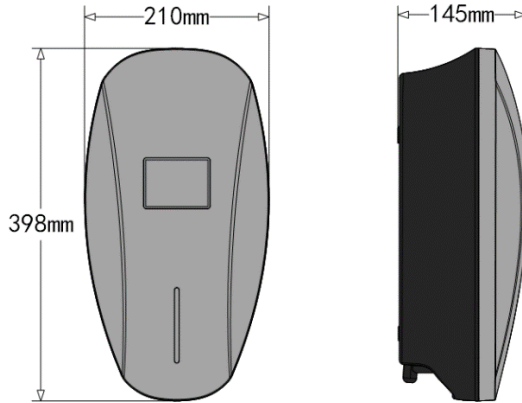

Fig. 4-1 The shape & dimensions of RASONIC

- The block diagram of RASONIC AC EV charging station is shown as Fig. 4-2.

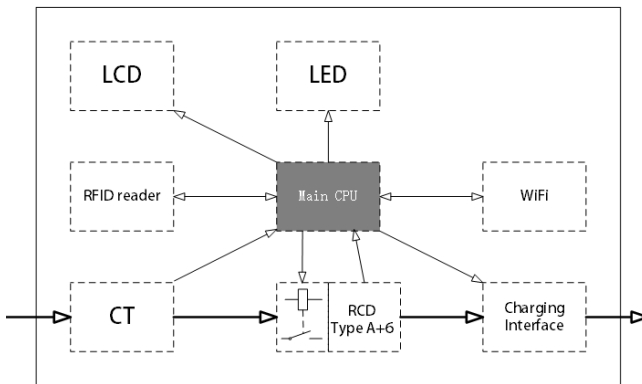

Fig. 4-2 Block diagram of RASONIC

- It is widely used in all kinds of household electric vehicle charging, as well as various charging stations, parking lots, community garages and public electric vehicle charging places.

4.2. Model number definition

The model number definition of RASONIC follows the rules as shown in Fig. 4-3.

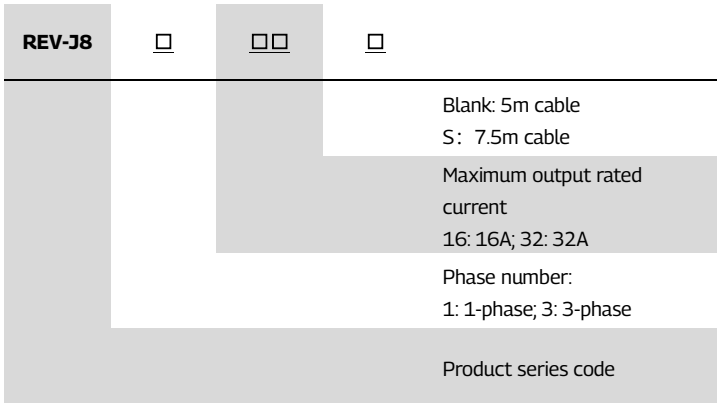

Fig. 4-3 Model number definition

4.3. Specifications

4.3.1. Electrical specifications

Model Number	REV-J8132	REV-J8132S	REV-J8332	REV-J8332S
Rated Voltage	230V, 50/60Hz		400V, 50/60Hz	
Rated Current	32A	32A	32A	32A
Rated Power	7kW (@230V, 1-phase)	7kW (@230V, 1-phase)	22kW (@400V, 3-phase)	22kW (@400V, 3-phase)
Recommended power supply cable	3×6mm ² , copper	3×6mm ² , copper	5×6mm ² , copper	5×6mm ² , copper
MCB recommended	Dedicated circuit, 40A, 2-Pole	Dedicated circuit, 40A, 2-Pole	Dedicated circuit, 40A, 4-Pole	Dedicated circuit, 40A, 4-Pole
Charging cable	5m	7.5m	5m	7.5m
Input Terminals	L/ N/ PE		L1/L2/L3/ N/ PE	
Charging interface	IEC 62196-2, Type 2, 1-phase (or 3-phase) plug with charging cable <i>Note: That cord extension sets are not be used</i>			

4.3.2. Functional description

Product Name		RASONIC
Charging Mode	Mode 3	
Charging Control	Remote: "APP-controlled" Local: "Button-controlled" or "Card-controlled"	
Indicator Lights	Multi-color atmosphere lights	
Networking interface	WiFi (2.4GHz), and support OCPP 1.6J Protocol	
Safety Protection	Surge protection, over temperature, over/under voltage, over current, leakage fault, ground protection for TN system (TN-C, TN-S and TN-C-S)	
RCMU Built-in	Yes, Type A (AC 30mA) + DC 6mA RCMU (meet IEC 62955) built-in	

4.3.3. Ambient conditions

Product Name		RASONIC
Altitude	≤ 2000m	
Storage temperature	-40 ~ 70℃	
Operation temperature	-30 ~ 50℃	
Relative humidity	≤ 95%RH, no water droplet condensation	
Vibration	< 0.5G, no acute vibration and impactation	
Installation location	Indoor or outdoor, good ventilation, no flammable, explosive gases	

4.3.4. Mechanical parameters

Product Name		RASONIC
Mounting	Wall-mounted or pole-mounted (mounting pole is optional)	
Net Weight	≤ 7kg	
Dimension	H×W×D = 398mm ×210mm × 145mm	
Color & Material	Front cover: Metallic Silver, PC+ASA; Back cover: Black PC+ASA	
IP Code	IP65	
IK Code	IK10	

4.4. Nameplate

On the RASONIC shell, there is a nameplate identifying the model and specification of the charging station, the content is shown as Fig. 4-4.

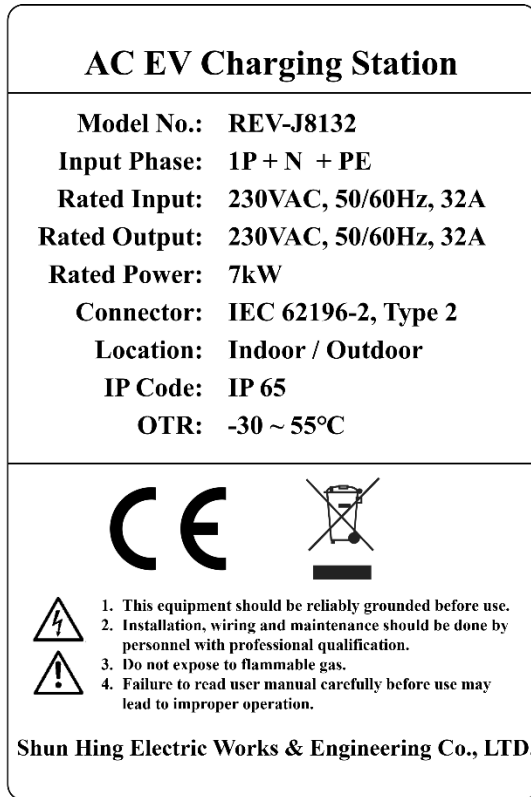

Fig. 4-4 The location and content of the nameplate

5. INSTALLATION

5.1. Unpacking

5.1.1. Packing list

Package	Quantity
RASONIC AC EV Charging Station	1 pc
Empty socket	1 pc
RFID card	2 pcs
Wall-mounting accessories (including A+B+C+D+E as Fig. 5-1 shown)	1 set
User manual	1 pc
Quality certificate	1 pc

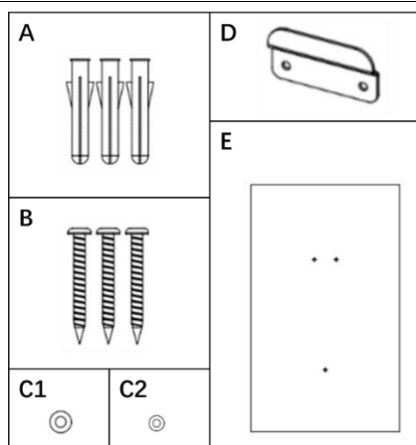

Fig. 5-1 Wall-mounting accessories

5.1.2. Inspection & confirm

When unpacking, please carefully confirm the following points:

- Whether the accessories are missing according to the packing list.
- Whether there is any damage during transportation.
- Whether the model and specification of the machine's nameplate are consistent with the order requirements.



- If any damage or missing parts are found, please do not start the machine and contact the supplier as soon as possible.
- Please keep the packing box and packing materials 1 month for future handling.



- The paper packaging is recyclable.

5.2. Prepare

- When transporting or moving the RASONIC, pay attention to the following points to ensure product safety:



- This product is electrical equipment. It should be handled with care to avoid violent vibration and impact.
- The charging station shall not be transported by dragging the charging connector and the charging cable.

- To ensure the long-term stable operation of the RASONIC, it is recommended to avoid installing RASONIC in extreme weather as far as possible, especially low or high ambient temperature may affect the installation effect due to thermal expansion and cold contraction.
- The electrical power supply cable must be prepared. Please refer to Clause 4.3.1 to select the power cable.
- Space requirement: When the charging station is fixed on the wall, the minimum space requirements are shown in Fig. 5-2.

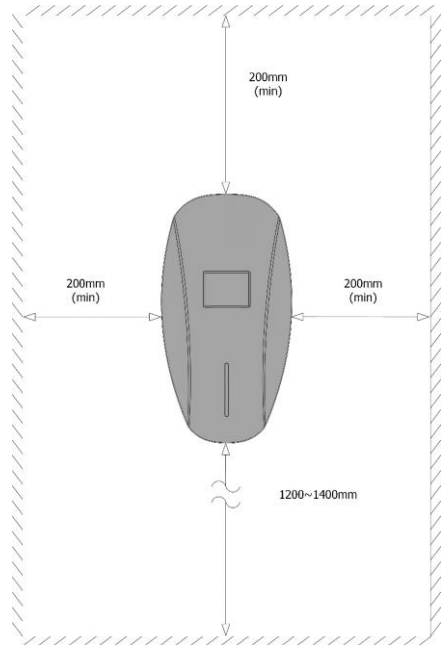









Fig. 5-2 Minimum space requirements for wall mounting

- It is suggested that the RASONIC should be installed in a place with good ventilation, no direct sunlight and shelter from wind and rain. To ensure good ventilation condition, you should mount the charging station vertically and leave enough space.

■ Tools for installation

Prepare the following tools at least before installing the RASONIC AC EV charging station.

Sr No.	Tools' Name	Schematic Picture	Main Uses
1	Multimeter		Check the electrical connection and measure the voltage
2	Electric Impact drill		Drill fixing holes in the wall
3	Wrench		Fastening bolt
4	Diagonal plier		Cut the cable
5	Wire stripper		Peeling cables
6	Crimping plier		Pressed cable terminal
7	Cross screwdriver		Fastening screw

5.3. Power supply system

RASONIC are suitable for installation in TN power supply system.

- a) TN-S power supply system wiring mode

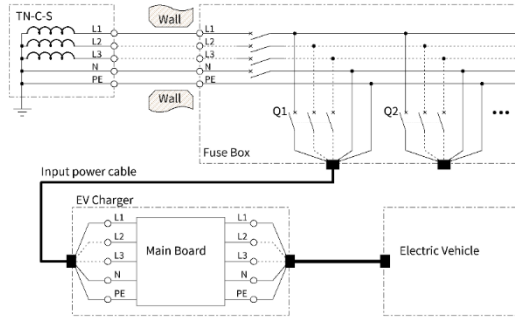

Fig. 5-3 RASONIC work in TN-S system

b) TN-C power supply system wiring mode

Earth rod should be installed as far as possible to ensure that household electrical equipment can be effectively protected zero connection. The Fig.5-4 shows the TN-C power supply system with earth rod.

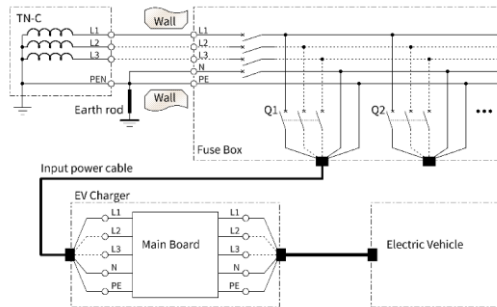

Fig. 5-4 RASONIC work in TN-C system with earth rod

In TN-C, for local earth rod where there is no condition to install, a series of circuits are set inside RASONIC to protect safety. Even if leakage fault occurs when PEN is disconnected or three-phase voltage is unbalanced, RASONIC can quickly interrupt charging and protect the personal safety of users.

c) TN-C-S power supply system wiring mode

The connection method is the same as that of TN-S power supply system.

5.4. Installation steps

Install the RASONIC on the wall follow the steps as below.

■ **Step 1: Drilling**



Fig. 5-5 Wall-mounting accessories-E

Drill 3 holes with diameter of 6mm and depth of at least 50mm on the wall using wall-mounting accessories-E.

■ **Step 2: Fixed the RASONIC**

As shown in Figure 5-6, use Mounting Accessory-A and Mounting Accessory-B to install Mounting Accessory-D on the wall;

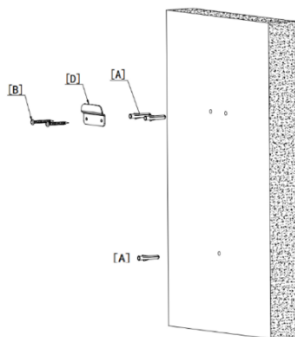

Fig. 5-6 Fixed the Wall-mounting accessories-D

As shown in Fig. 5-7, Use tools to open decorative covers and sealing covers.

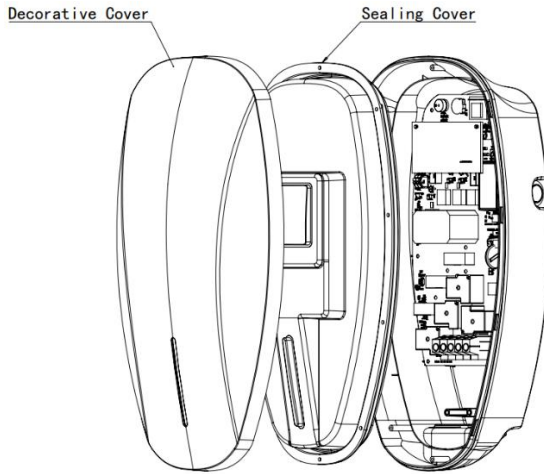

Fig. 5-7 Open the lid

As shown in Figure 5-8,

First step: install the RASONIC on the wall in the direction of the arrow;

Second step: use the installation accessories-B and the installation accessories-C to fix the RASONIC.

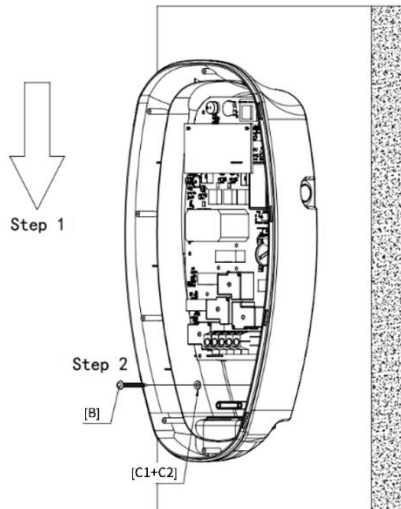
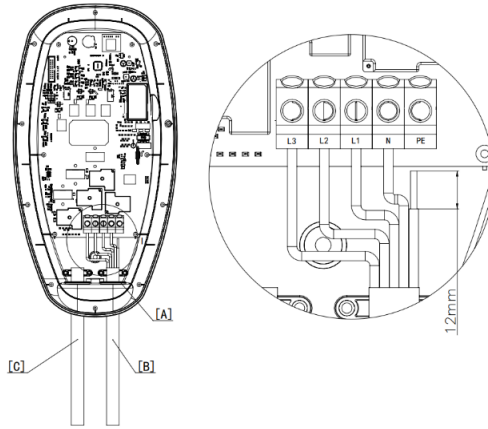

Fig. 5-8 Install the RASONIC

■ **Step3: Wiring**



[A] Rubber grommet [B] Input power cable [c] Charging cable

Fig. 5-9 Wiring

As shown in Fig. 5-9,

1. Pass the prepared power cable through the rubber grommet [A];
2. Remove the 12mm insulation layer on the wire;
3. According to the label number on the terminal, insert the wire into the corresponding terminal, and tighten the screws to ensure that each reliable connection between wires and terminals.

■ **Step4: Close the lid**

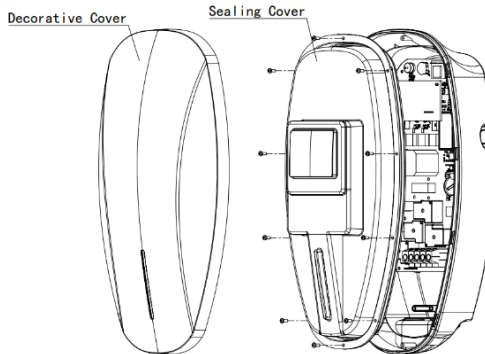

Fig. 5-10 Close the lid

As shown in Fig. 5-10,

1. Install the sealing cover on the wall box with the removed screws (ten screws in total). Please ensure that the installation is firm after installation;
2. Install the decorative cover on the wall box. The decorative cover is installed by means of snaps, please ensure that the installation is firm.

5.5. Empty socket

RASONIC AC EV charging station config a type 2 charging connector. When the RASONIC is in standby state, please plug the charging connector in the empty connector socket to protect the charging connector. Please use expansion screws to fix this empty socket at a suitable position beside the RASONIC.

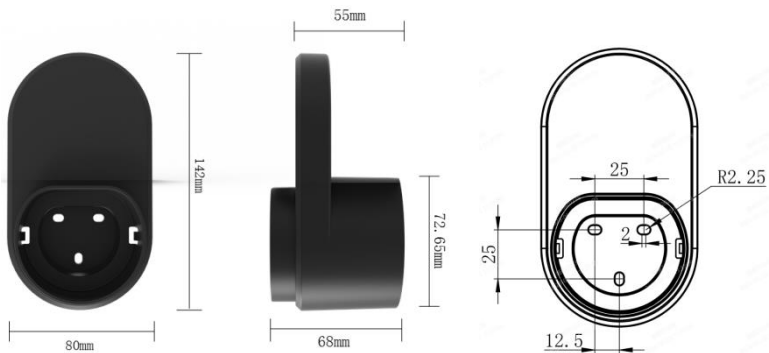

Fig. 5-11 Empty socket

6. OPERATION

6.1. Power on

After the RASONIC has been installed and confirmed, switch on the power supply. The light and screen lights up and the RASONIC enters standby state. It is recommended that RASONIC can start to operate after entered standby state for 30 seconds.

6.2. Human-Machine Interface

6.2.1. Overview

As shown in Fig. 6-1, RASONIC is configured with multiple human-machine interfaces.

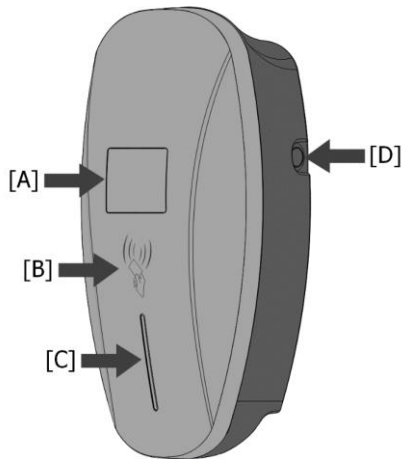

- [A] **Screen display area:** A screen used to display system status
- [B] **Swipe card area:** Swipe the RFID card to charging
- [C] **Indicator lights:** It is used to show indicate system status
- [D] **Charging control button:** Start or stop charging by press for Button-controlled charging

Fig. 6-1 HMI of RASONIC

6.2.2. LCD indicators

The screen is used to display the running status of RASONIC, which is convenient for users to know the real-time situation of RASONIC. In the status bar of the upper part, the accumulated charging electric energy and CP status of WIFI is displayed. The pile number and fault code are listed on the status bar in the following section:

① Standby state

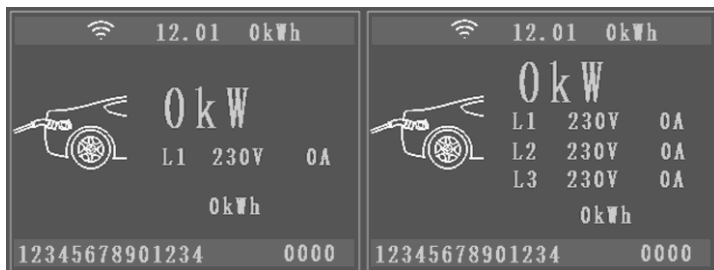

② Connection status



③ Charging status



④ System failure



⑤ System upgrade



⑥ Scan the QR code binding



6.2.3. RFID reader

In general, the RASONIC is equipped with RFID card reader as standard, and the charging process can be started and stopped by using the RFID card (shown as Fig. 6-2) configured with the host. The special customized card swiping function is not separately described here.

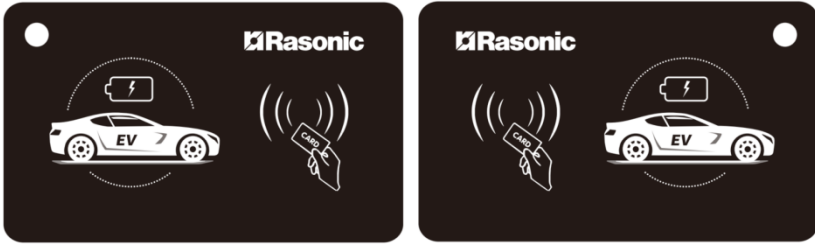

Fig. 6-2 RFID card

6.2.4. LED indicators

The LED indicators on the panel are used to indicate the status of the charging station and the various combinations of indicators are described as below.

No.	Indicator Color	Indicator Status	Connotation
1	Green	ON	Standby status
		Breath	Connecting to the server
2	Blue	ON	Connected to an EV
		Twinkle	Start charging state
3	Purple	Breath	Charging status
		Twinkle	Charge end
4	Red & Yellow	Yellow ON Red OFF	Ground fault
		Twinkle	System failure: Blinking red Indicates the high level of the fault code. Blinking yellow indicates the low level of the fault code

6.2.5. Charging control button

You can press the button to control charging, when RASONIC work in button-controlled mode.

Mode 1:

- Start charging: plug the charging connector into EV socket, press button to start charging.
- Stop charging: press button again will end the charging, when EV is in charging.

Mode 2:

- Start charging: plug the charging connector into EV socket, it starts charging

automatically.

- Stop charging: press button will end the charging, when EV is in charging.

6.3. Configure parameters

Taking the configuration of charging station parameters by laptop as an example, it is introduced as follows (the method of setting parameters by mobile phone is similar and will not be repeated):

- Step 1: connect to WiFi hotspot

Keep your laptop in a state where it can connect to WiFi hotspot. Within ten minutes after power on, the charging station provides a WiFi hotspot as the access entrance for parameter configuration. Connect a WiFi hotspot with a name is like "EVSE-12345678" in the "WiFi network" of the laptop. It is no password to connect the hotspot.

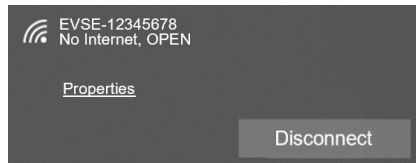

Fig. 6-3 Connect the WiFi in Windows OS

- Step 2: login to setting

Enter 192.168.4.1 in the address bar of Google Chrome or Microsoft Edge, you can access the EVSE CONFIGURATION shown in Fig. 6-4, and Microsoft IE cannot access this IP address.

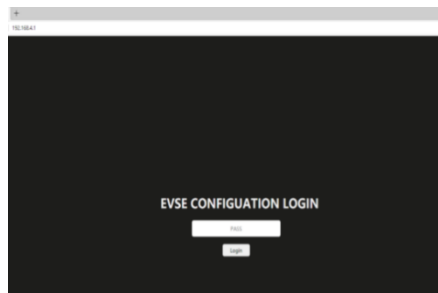

Fig. 6-4 Login of EVSE CONFIGURATION

- Step 3: Config your RASONIC AC EV Charging station

Enter the correct login password to enter the page shown in Fig. 6-5. The factory default

password is 12345678. Please change the password upon your first login.

As shown in Figure 6-5, set parameters in this interface, the left is the interface of single-phase products, the right is part of the interface of three-phase products, they have a little difference, if you purchase the three-phase version, when setting parameters, the "Power supply type" mode, please select "three-phase"

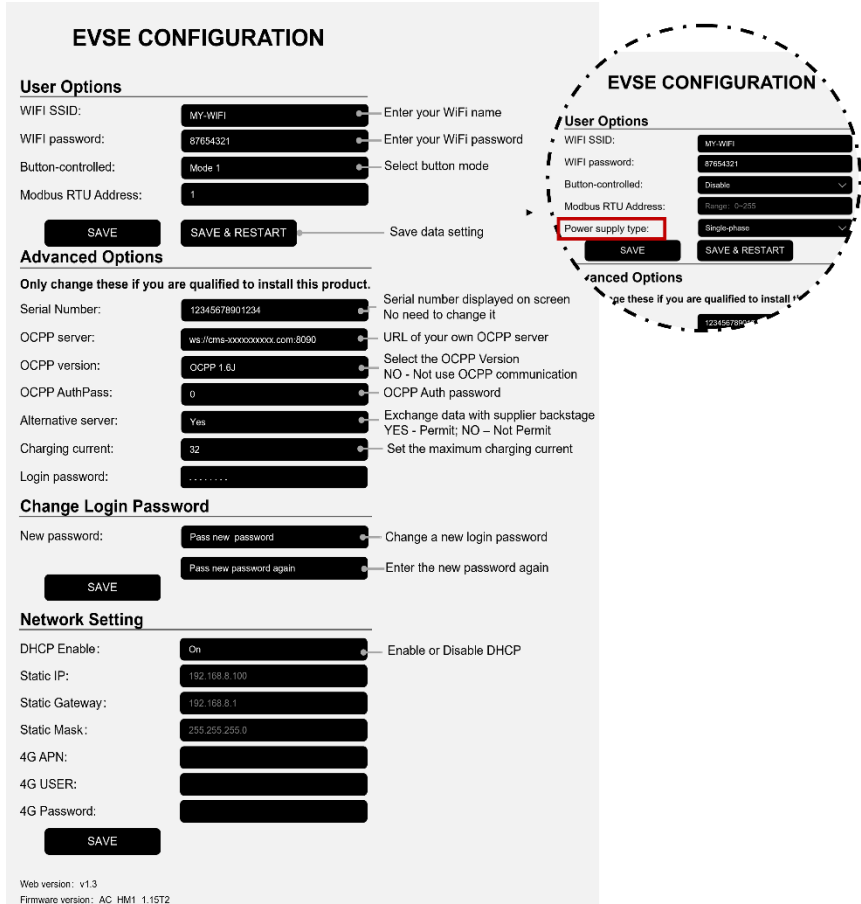

Fig. 6-5 Set parameters to config the EV charging station

After setting, click the "SAVE" button to save the settings, click the "SAVE & RESTART" button to restart charging station for settings take effect. Enter your WiFi name and password in the

page. After it takes effect, the charging station can access Internet via your WiFi.

6.4. Start Charging

- a) Park your EV into place, turn off, and put the EV under braking.
- b) Pick off the charging connector from empty socket of EV charging station.
- c) As shown in Fig.6-6, plug the charging connector into the AC charging socket of the EV.
- d) For the charging control mode of "Button-controlled", press the button after EV connector plug in, the charging will start automatically (if button-controlled mode chosen mode 1).



Fig. 6-6 Plug into EV socket

- e) For the charging control mode of "Card-controlled" or "APP-controlled", you can control charging process by swipe RFID card or APP after charging connector plug in.



- If you want to scan QR code on the screen to start charging, please download and install the Rasonic EVC APP on your smart phone.



Rasonic EVC

- For Android phone, search "**Rasonic EVC**" in Google Play or scan the QR code on the right to install APP.



- For iPhone, search "**Rasonic EVC**" in APP Store or scan the QR code on the right to install APP.



- The user manual of APP please refer to the FAQ of APP.

6.5. Normally stop charging

- a) The RASONIC will automatically stop when the electric vehicle is fully charged.
- b) For the charging control mode of “Button-controlled”, you can stop charging by press button again, when EV is in charging.
- c) For the charging control mode of “Card-controlled”, you can stop charging by swipe your RFID card again, when EV is in charging.
- d) For the charging control mode of “APP-controlled”, click the stop button on your APP, the charging will stop.
- e) When the charging is end, please unplug the charging connector and plug back to the empty socket of charging station.

6.6. Abnormally stop charging

- a) Forced fault stop: A fault stop initiated by the onboard charger of vehicle.
- b) Automatic fault stop: A fault stop initiated by the charging station.

7. FAULT HANDLING AND MAINTENANCE

7.1. Fault Handling

The RASONIC is automatically protected in the event of the fault. The fault information and handling methods are as follows.

LED indicator information	Fault code	Handling method
LED are not on	-	<ul style="list-style-type: none"> ● Check whether the power supply and distribution are normal; ● Check whether the branch breaker is tripped, and close the breaker after troubleshooting; ● Check whether the connection is correct, if the cable comes off, should be properly connected to tighten the cable.
<ul style="list-style-type: none"> ● LED flash: Red×1+Yellow×1 	Fault code 11: CP voltage anomaly	<ul style="list-style-type: none"> ● Check the connection of charging connector and EV socket. ● Disconnect and reconnect the charging connector.
<ul style="list-style-type: none"> ● LED flash: Red×1+Yellow×3 	Fault code 13: Undervoltage input	<ul style="list-style-type: none"> ● Check whether the input cable is reliably connected. ● Check whether the input voltage is abnormal.
<ul style="list-style-type: none"> ● LED flash: Red×1+Yellow×4 	Fault code 14: Overvoltage input	<ul style="list-style-type: none"> ● Check whether the input cable is connected correctly. ● Check whether the input voltage is abnormal.
<ul style="list-style-type: none"> ● LED flash: Red×1+Yellow×5 	Fault code 15: Over-temperature protection	<ul style="list-style-type: none"> ● Check whether the charging station is covered or installed in a high temperature environment.
<ul style="list-style-type: none"> ● LED flash: Red×1+Yellow×7 	Fault code 17: Leakage protection	<ul style="list-style-type: none"> ● Check whether the charging connector and its cable are damaged or wet. ● Recover after pulling out the adapter.
<ul style="list-style-type: none"> ● LED flash: Red×1+Yellow×8 	Fault code 18: Output shortage	<ul style="list-style-type: none"> ● Check whether the charging adapter and its cables are damaged or wet.
<ul style="list-style-type: none"> ● LED flash: Red×1+Yellow×9 	Fault code 19: Output overcurrent	<ul style="list-style-type: none"> ● Check whether the charging connector is correctly connected. ● Check whether the OBC is normal. ● Check the set of output current.

LED indicator information	Fault code	Handling method
<ul style="list-style-type: none"> ● LED flash: Red×2+Yellow×1 	<ul style="list-style-type: none"> ● Fault code 21: EV response timeout 	<ul style="list-style-type: none"> ● Battery of EV is full. Or the charging connector is not properly connected. ● Disconnect and reconnect the charging connector.
<ul style="list-style-type: none"> ● LED flash: Red×2+Yellow×2 	<ul style="list-style-type: none"> ● Fault code 22: EV not supported 	<ul style="list-style-type: none"> ● This EV does not meet the IEC standards and cannot be charged.
<ul style="list-style-type: none"> ● LED flash: Red×2+Yellow×3 	<ul style="list-style-type: none"> ● Fault code 23: Relay sticking 	<ul style="list-style-type: none"> ● The device is damaged and needs to be returned to the factory for repair.
<ul style="list-style-type: none"> ● LED flash: Red×2+Yellow×4 	<ul style="list-style-type: none"> ● Fault code 24: RCD fault 	<ul style="list-style-type: none"> ● The RCD is damaged and needs to be returned to the factory for repair.
<ul style="list-style-type: none"> ● LED always on: Yellow 	<ul style="list-style-type: none"> ● Fault code 25: Ground fault 	<ul style="list-style-type: none"> ● Charging station is not grounded; input power cable needs to be checked.
<ul style="list-style-type: none"> ● LED flash: Red×2+Yellow×6 	<ul style="list-style-type: none"> ● Fault code 26: PEN fault 	<ul style="list-style-type: none"> ● The ground cable has leakage current, and the charging pile needs to be restarted

7.2. Maintenance

To ensure the long-term stable operation of the equipment, please maintain the equipment regularly (usually every month) according to the operating environment.

- The equipment is maintained by professionals.
- Check whether the equipment is well grounded and safe.
- Check whether there are potential safety hazards around the charging pile, such as whether there are high temperature, corrosion or inflammable and explosive articles close to the charging station.
- Check whether the join point of the input terminal is in good contact and whether there is any abnormality. Check whether other terminal points are loose.

8. TECHNICAL GUIDELINES ON CHARGING FACILITIES FOR ELECTRIC VEHICLES

Reference to EMSD

https://www.emsd.gov.hk/en/electricity_safety/publications/guidance_notes_guidelines/index.html

Reference to CLP Power Hong Kong Limited

<https://www.clp.com.hk/en/business/low-carbon-solutions/emobility/about-electric-vehicles>

Reference to HK Electric Investments Limited

<https://www.hkelectric.com/en/smart-power/ev-charging>

9. SPECIAL AVOWAL

1. The information above has been checked. Our company reserves the hermeneutic power to any printing errors or misunderstanding on the content.
2. If there are technical improvements on the appliance, the operation manual will be updated without any prior notice. The product appearance and color are subject to the actual appliance.
3. The e-copy of user manual can be sent by e-mail on requested, please call Shun Hing Electric Works & Engineering Co. Ltd. hotline at 2861 2767.

10. AFTER SALES SERVICES

For any defect, in the judgment of technician from Shun Hing Electric Service Centre Limited, caused under normal use, we are responsible for repairing or replacing parts of the said electrical appliance free of charge within one year guarantee period commencing from the date of purchase. Any defective part which has been replaced shall become our property. Guarantee service does not cover the repair or replacement of accessories, external cables or cabinet, etc. Additional charges shall be levied if services are required.

Please present the official invoice and the guarantee certificate with the sales point's chop or the redemption center's chop for free maintenance. For enquiries, please call Shun Hing Electric Service Centre Limited hotline at 2406 5666.

Free guarantee service will not be provided to the AC EV charging station if: 1) it has been

explicitly or implicitly modified, tampered with, altered or repaired in any way by persons other than technicians of the Company. Or 2) it has been damaged through misuse, negligence, liquid ingress or corrosion, power interruption, natural calamities or accident or external factors. Or 3) it is not a fixed installation on land. Or 4) the normal operation of the AC EV charging station is affected by improper installation. Or 5) the domestic model of AC EV charging station is used for industrial or commercial purpose. Or 6) the change of location or ownership of the AC EV charging station and did not inform Shun Hing Electric Service Centre Limited.

DECLARATION OF CONFORMITY(DOC)

We, declare that the construction of the device described in the following complies with the relevant stated below.

Relevant EC directives: Directive 2014/53/EU on radio equipment and telecommunications terminal equipment (RED Directive 2014/53/EU).

Harmonized EN basic and engineering standards: IEC 61851-21-2, EN 301489-1/-17, EN 300328, EN 300330, EN 61000-3-11/-12.



COMPLIANCE STATEMENT OF WEEE

This product cannot be discarded at will when it is abandoned. It must be collected separately for special treatment.



Rasonic 樂信牌



SHUN HING GROUP
信興集團
SINCE 1953

信興電工工程有限公司

SHUN HING ELECTRIC WORKS & ENGINEERING CO., LTD

辦公室: 香港九龍尖沙咀東部麼地道 67 號半島中心 9樓

OFFICE: 9/F, PENINSULA CENTRE, 67 MODY ROAD, TSIMSHATSUI EAST, KOWLOON, HONG KONG

電話 TEL: (852) 2861 2767

傳真 FAX: (852) 2865 6706

網址 WEBSITE: www.rasonic.com

電郵 EMAIL: shew@shunhinggroup.com

保養及維修 MAINTENANCE AND REPAIR SERVICE

信興電器服務中心有限公司

SHUN HING ELECTRIC SERVICE CENTRE LTD.

辦公室: 香港新界葵涌勝耀街2號信興中心11樓

OFFICE: 11TH FLOOR, SHUN HING CENTRE, 2 SHING YIU STREET, KWAI CHUNG, NEW TERRITORIES, HONG KONG

電話 TEL: (852) 2406 5666

傳真 FAX: (852) 2408 0316

網址 WEBSITE: www.shesc.com

消耗品/附件銷售熱線 CONSUMABLES/ ACCESSORIES SALES HOTLINE

電話 TEL: (852) 2406 5666

客戶服務中心 CUSTOMER SERVICE CENTRES

香港新界葵涌勝耀街2號信興中心1樓

1ST FLOOR, SHUN HING CENTRE, 2 SHING YIU STREET, KWAI CHUNG, NEW TERRITORIES, HONG KONG

電話 TEL: (852) 2406 5439

傳真 FAX: (852) 2408 1389

澳門慕拉士大馬路193-199號南嶺工業大廈5樓1座

AVENIDA DE VENCESLAU DE MORAIS, NO. 193-199, 5 ANDAR-I, EDF. INDUSTRIAL NAM LENG, MACAU

電話 TEL: (853) 2836 2928

傳真 FAX: (853) 2833 6405

有關最新之客戶服務中心資訊, 請參閱信興服務中心網址: www.shesc.com或致電維修服務熱線查詢。

For the latest information of customer service centres, please visit www.shesc.com or call us at our hotline.

REV/I/2406

**We provide customers
with all-round technical support.**



Any change without prior notice.